

SEEPEX.
ALL THINGS FLOW

TO THE EXACT DROP PRODUCT GROUP D



D

FOR HIGHEST PRECISION

SEEPEx metering pumps have highly repeatable accuracy. They're used to handle thin to highly viscous products that can be entrained with or without solids and are corrosive, all with low pulsation and to the exact drop.

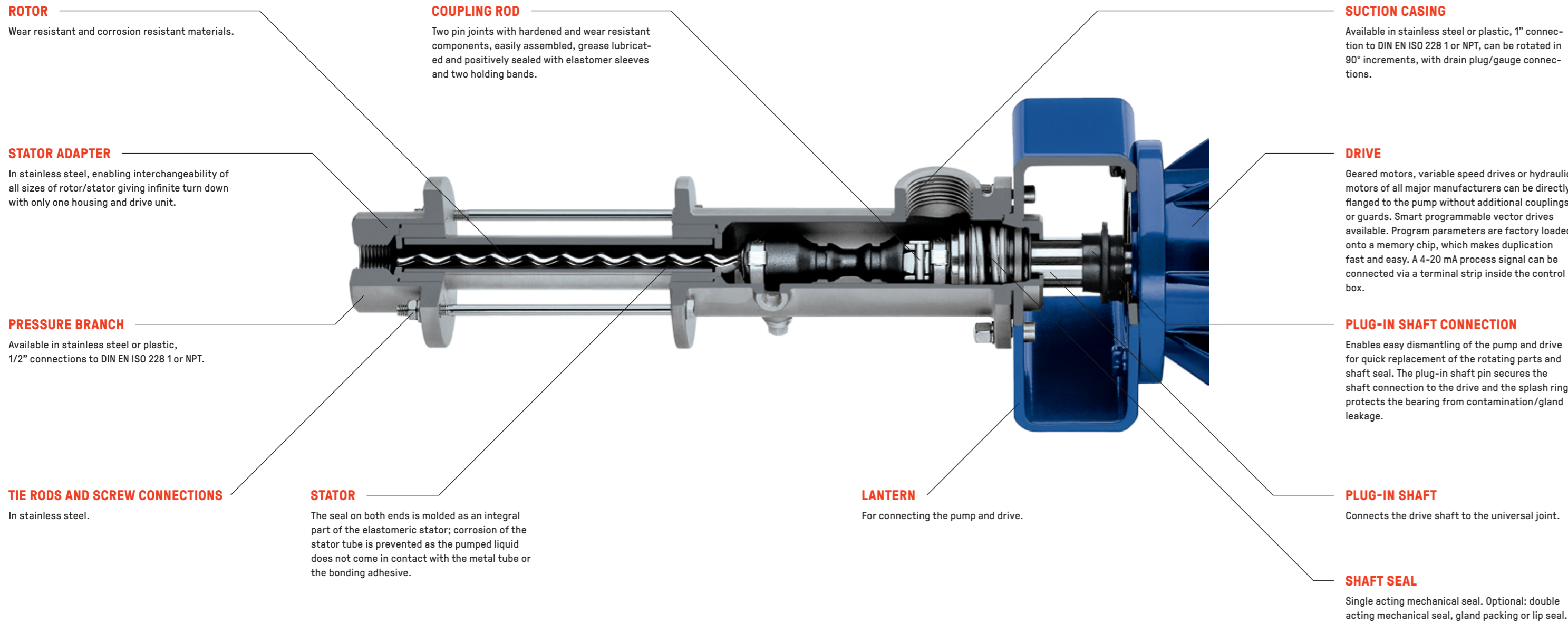

OVERVIEW OF RANGES

MD RANGE

The modular design of the MD range incorporates six sizes of metering pumps which are available with stainless steel or plastic casings. Rotating components are also manufactured from Hastelloy or Titanium. These pumps are the ideal choice for low pulsation metering of low to highly viscous fluids with or without entrained solids and are chemically aggressive.

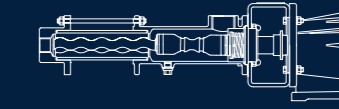

MDP RANGE

The MDP range pumps are available with stainless steel or plastic housings. A special feature is the one-piece, wear resistant plastic rotating unit without joint.

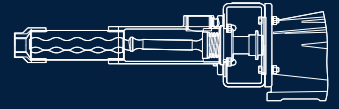

MDT RANGE

The MDT range pumps feature a rectangular open hopper with a compression zone and an auger feed screw. The length of the hopper opening is variable to suit the installation requirements. They are used for pumping highly viscous products with or without entrained solids. The MDT range is equipped with the proven closed pin joint.

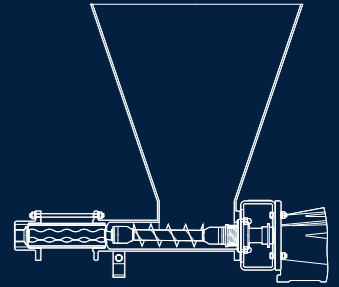

MDC RANGE

The MDC range of pumps are equipped with open barrel-shaped pin joints that can be cleaned without leaving residues through CIP cleaning. They meet the highest demands of cleanliness, safety and corrosion or wear resistance. Service work can be performed easily and rapidly without the need for special tools. They are built with FDA compliant components, certified acc. to the 3-A Sanitary Standards (USA) and designed in compliance with the EHEDG directives.

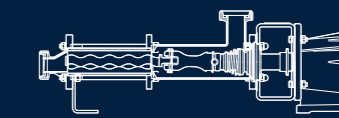

MDTC RANGE

The MDTC range features a rectangular open hopper with a compression zone and an auger feed screw which assists the product into the pumping elements, the rotor and stator. The length of the hopper opening is variable to suit the application conditions. They are used for pumping highly viscous products with or without entrained solids. The MDTC range pumps are equipped with open barrel-shaped pin joints that can be cleaned without leaving residues through CIP cleaning. They meet the highest demands of cleanliness, safety and corrosion or wear resistance. Service work can be performed easily and rapidly without the need for special tools. They are built with FDA compliant components, certified acc. to the 3-A Sanitary Standards (USA) and designed in compliance with the EHEDG directives.

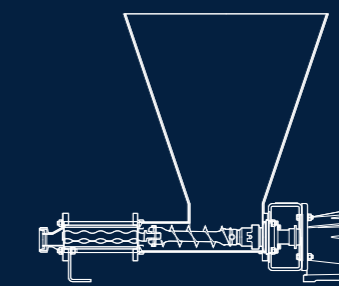

MDF RANGE

The MDF range pumps are used for emptying barrels with a 2" hole. The liquid level in the container provides a positive feed. These pumps are ideal for handling thin to highly viscous products and ensuring complete emptying. The pump can be easily transported by a handle attachment.

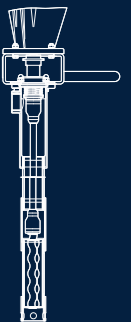

APPLICATIONS

The six ranges of metering pumps can be used in virtually all industries for metering and dosing precise quantities. They are particularly good for low-pulsation conveying of thin to high viscosity fluids, as well as corrosive media containing solids.

They are used for applications in agriculture; automotive assembly; bakeries; building products; ceramics; chemical and biochemical processing; coating kitchens, stock preparation and deinking in paper mills; confectioneries; dairies; distilleries; dye and ink plants; fruit and vegetable processing; pharmaceuticals, cosmetics and personal care products; poultry, meat and fish processing; oil, gas and petrochemicals; ship building; sewage sludge dewatering; wastewater treatment; water purification; wineries and wood treatment and fabrication.

FEATURES

- Simple interchangeability due to their modular construction
- Infinite turn down
- Low pulsation, no pulsation dampers required
- Constant flow, independent of pressure
- Low shear characteristics
- High metering accuracy
- Valveless flow control
- No check valves, no gas locking or blocking by solids
- Drive options and control systems available that allow user-friendly metering applications

KEY FACTS

- Conveying capacity:
1 cc/min.–1,000 l/h
0.06 l/h–1,000 l/h (0.016–264 USGPH)
- Pressure:
up to 24 bar (360 psi)